

2.4~2.5 GHz RF Front-End Module

Introduction

The FM2422U is a fully integrated RF front-end module designed for dual-mode 802.11b/g WLAN applications. The device includes T/R switch, a low noise amplifier with band-pass filter, a low-current linearized power amplifier (LPA), low-pass filter (LPF), and power detector. Biasing and matching circuitry are all integrated to minimize the external components required.

The device is sold in a RoHS compliant miniature 4 x 4 x 0.5 mm 24-pin QFN package to make automated assembly simple. Its small and thin package size makes the device an ideal solution for radios built in small form factors for mobile applications.

Applications

- IEEE 802.11b DSSS WLAN
- IEEE 802.11g OFDM WLAN
- 2.4 GHz Cordless Phones
- 2.4 GHz ISM Radios

Pin Assignment

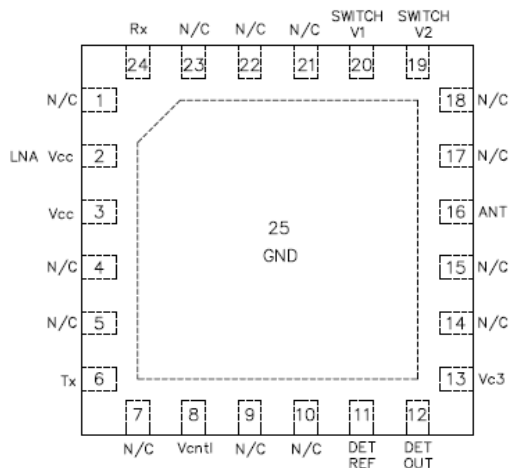

< Top View >

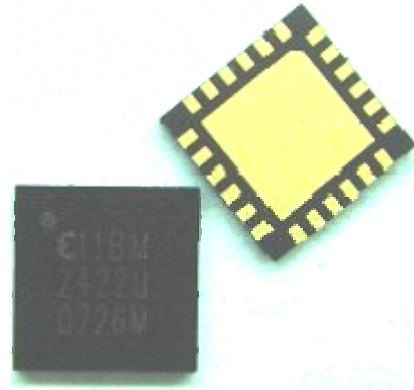

Features

- 2.4 to 2.5 GHz Operating Range
- 24 dB Gain
- 802.11b/g ACPR compliant up to +18dBm
- 3% EVM at Pout=+14.5 dBm with low Icc=60mA at 54 Mbps OFDM signal
- On-chip power detector
- +3.3V Supply
- Miniature size: 4 x 4 x 0.5 mm 24-pin
- RoHS compliant product



Caution!
ESD sensitive device



Pin Description

Pin	Pin Name	Pin Description
1	N/C	No connection
2	LNA Vcc	LNA Bias Voltage
3	Vcc	2.4 GHz PA Vcc
4	N/C	No connection
5	N/C	No connection
6	Tx	2.4 GHz Tx input
7	N/C	No connection
8	Vcntl	2.4GHz PA control voltage
9	N/C	No connection
10	N/C	No connection
11	DET REF	Detector reference bias voltage
12	DET OUT	Detector output voltage
13	Vc3	2.4 GHz PA Vcc
14	N/C	No connection
15	N/C	No connection
16	ANT	RF output Ant
17	N/C	No connection
18	N/C	No connection
19	SWITCH V2	SW control voltage 2
20	SWITCH V1	SW control voltage 1
21	N/C	No connection
22	N/C	No connection
23	N/C	No connection
24	Rx	2.4 GHz Rx output
25	GND	Package backside ground slug

Functional Diagram

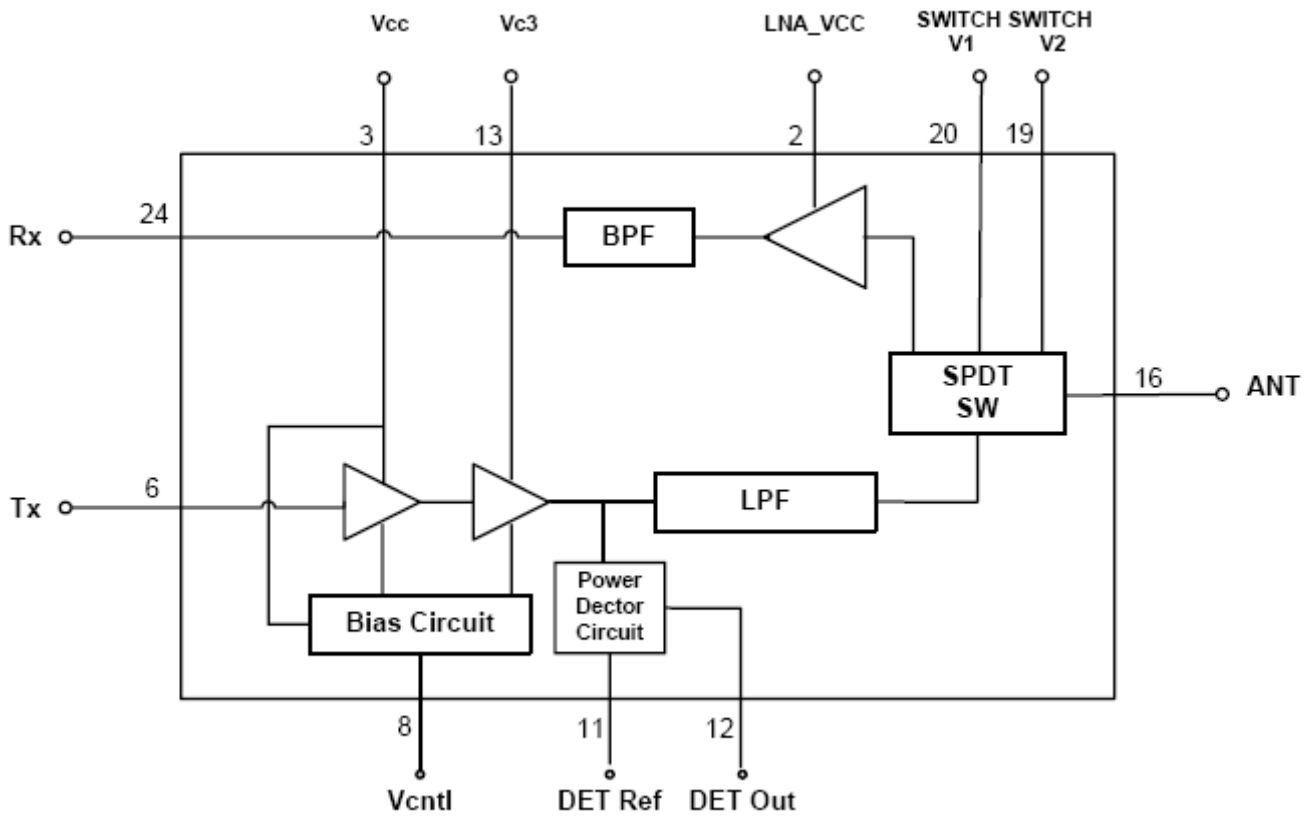

Truth Table

State	V1	V2	ANT
1	'0'	'1'	TX
2	'1'	'0'	RX

V1, V2: '0' = 0 to +0.2V, '1' = +3 to +5V

Specifications

Absolute Maximum Ratings

PARAMETER	RATING
Vcc, Vc3, Vcntl	-0.5V to +4.5V
Operating Temperature Range	-20°C to +85°C
Storage Temperature Range	-65°C to +125°C
Soldering Conditions	260°C peak for 20 seconds

DC Electrical Characteristics (Temp.=25°C)

PARAMETER	CONDITIONS	MIN.	TYP.	MAX.	UNIT
Supply Voltages					
Vcc/Vc3		3.0	3.3	3.6	Volts
Vcntl			2.8		Volts
Supply Currents					
Icc + Ic3	Quiescent (no RF)		23		mA
Icntl			4		mA

AC Electrical Characteristics (Vcntl = 2.8V, Temp.=25°C)

PARAMETER	CONDITIONS	MIN.	TYP.	MAX.	UNIT
RF Frequency Range (Note)		2.4		2.5	GHz
Power Gain	Vcc = 3.3V		24		dB
S11 (Input Return Loss)			-10		dB
S22 (Output Return Loss)			-10		dB
Isolation : Tx – Antennas			15		dB
P1dB	Vcc/Vc3 = 3.3V		21		dBm
Bias current @3.3V	Quiescent 64QAM/54Mbps, Pout=14.5dBm		23 60		mA
Sleep Mode current	Vcc = 3.3V, Vcntl = 0V		2		uA
Detector voltage range	64QAM/54Mbps, Pout=10dBm 64QAM/54Mbps, Pout=16dBm 64QAM/54Mbps, Pout=18dBm		120 400 610		mV
ACPR 1 st Side Lobe	11b, 1 Mbps Long, Pout=19 dBm		-33		dBc
ACPR 2 nd Side Lobe	11b, 1 Mbps Long, Pout=19 dBm		-53		dBc
2 nd Harmonics	Pout=19 dBm		-60		dBc
EVM	64QAM/54Mbps, Pout=14.5dBm		3		%

Note : Operation outside this range is possible, but not guaranteed

Receive Path Electrical Characteristics (Temp.=25°C)

PARAMETER	CONDITIONS	MIN.	TYP.	MAX.	UNIT
Frequency Range (Note)		2.4		2.5	GHz
Gain			8		dB
S11 (Input Return Loss)			-20		dB
S22 (Output Return Loss)			-15		dB
Isolation : Rx - Antennas			16		dB
Bias current			12		mA
Noise Figure			3		dB
IP1dB			-6		dBm

Note : Operation outside this range is possible, but not guaranteed

Ordering Information

Ordering Number	Component Packing
FM2422U	1000pcs / Tape & Reel
FM2422U-EVB	FM2422U Evaluation Kit

**For additional product information, please contact
sales@epic.com.tw**

Epic Communications Inc. reserves the right to make changes to the product(s) or information contained herein without notice. The information contained in this document is considered to be accurate as of the date of publication. No liability is assumed by Epic Communications Inc. for use of any information contained in this document, or for infringement of any patent rights or any other proprietary rights of third parties which may result from such use.