

## 5 GHz Linearized Power Amplifier

### Introduction

The PA5305 is a three-stage linearized power amplifier optimized for 802.11a wireless LAN (WLAN) applications in the 4.9~5.9 GHz band. The device is designed to operate from a single 3.3V supply and it does allow for separate control of three stages, allowing the user to choose the optimum balance between output power/efficiency and linearity for particular application. It features 20 dB of gain and delivers up to +22 dBm of output power.

The device is sold in a RoHS compliant miniature 3 x 3x 0.8 mm 16-pin QFN package to make automated assembly simple. Its small and thin package size makes the device an ideal solution for radios built in small form factors for mobile applications.

### Applications

- IEEE 802.11a OFDM WLAN
- 5 GHz Cordless Phones
- 5 GHz ISM Radios

### Pin Assignment

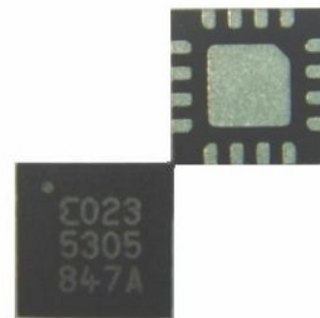
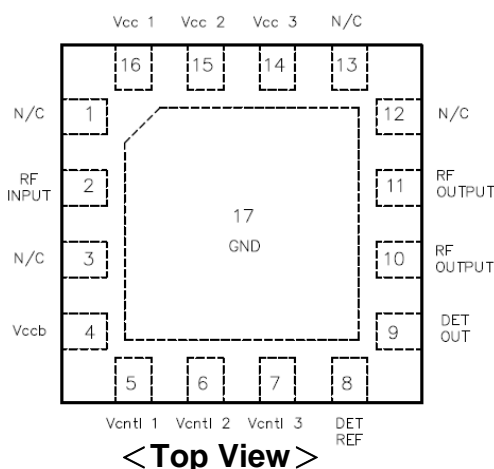

### Features

- 4.9~5.9 GHz Operating Range
- 20.5dB Gain
- 802.11a/54Mbps-less than 3% EVM at Pout=+14dBm with low Icc=175mA
- On-chip power detector
- +3.3V Single Supply
- Miniature size:3 x 3 x 0.8 mm 16-pin
- RoHS compliant product



**Caution!**  
ESD sensitive device



### Pin Description

Pin	Pin Name	Pin Description
1	N/C	No connection
2	RF INPUT	RF input
3	N/C	No connection
4	Vccb	Vcc for Bias network
5	Vcntl 1	PA control voltage
6	Vcntl 2	PA control voltage
7	Vcntl 3	PA control voltage
8	DET REF	Detector reference bias voltage
9	DET OUT	Detector output voltage
10	RF OUTPUT	RF output
11	RF OUTPUT	RF output
12	N/C	No connection
13	N/C	No connection
14	Vcc3	PA Vcc
15	Vcc2	PA Vcc
16	Vcc1	PA Vcc
17	GND	Package backside ground slug

### Functional Diagram drawing

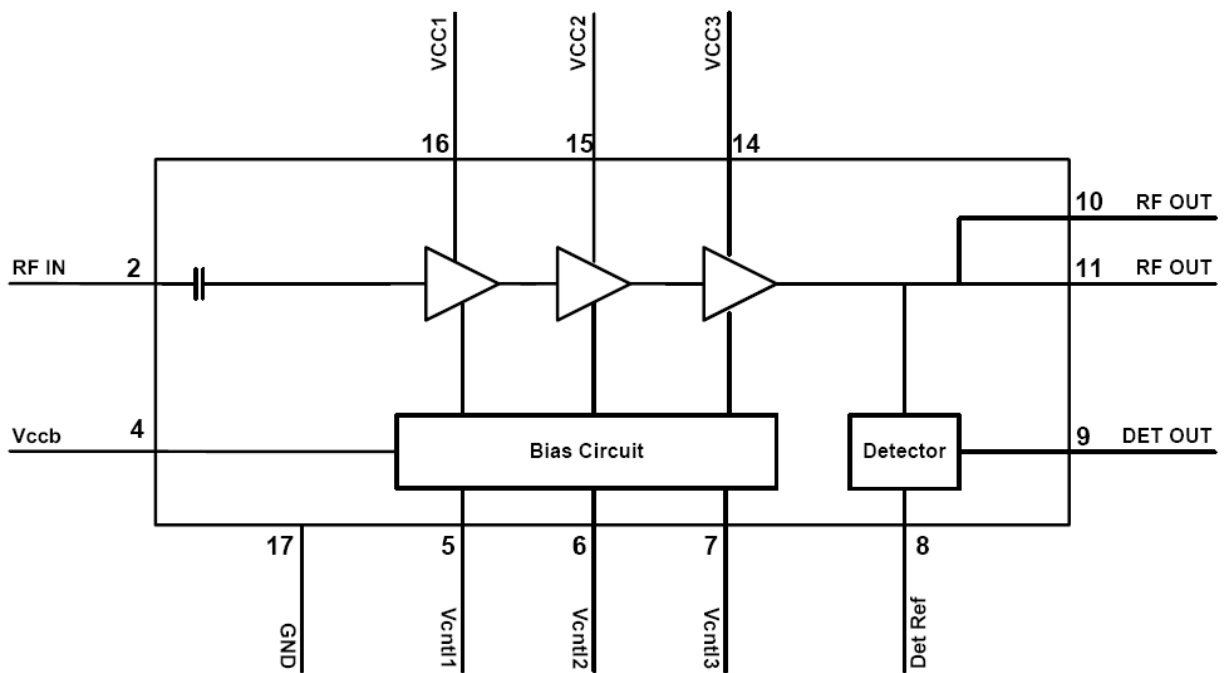

## Specifications

### Absolute Maximum Ratings

Vcc1, Vcc2, Vcc3, Vcntl, Vcntl2, Vcntl3	-0.5V to +4.5V
Operating Temperature Range	-20°C to +85°C
Storage Temperature Range	-65°C to +125°C
Soldering Conditions	260°C peak for 20 seconds

### DC Electrical Characteristics (Temp.=25°C)

PARAMETER	CONDITIONS	MIN.	TYP.	MAX.	UNIT
<b>Supply Voltages</b>					
Vcc1		3.0	3.3	3.6	Volts
Vcc2		3.0	3.3	3.6	Volts
Vcc3		3.0	3.3	3.6	Volts
Vcntl 1	Rb=300Ω		3.0		Volts
Vcntl 2	Rb=160Ω		3.0		Volts
Vcntl 3	Rb=160Ω		3.0		Volts
<b>Supply Currents</b>					
Ic1+Ic2+Ic3	Quiescent (no RF) Pout = +14dBm		150 175		mA
Icntl+2cntl+3cntl			5		mA

### AC Electrical Characteristics (Temp.=25°C, Vcc=3.3V, Vcntl=3.0)

PARAMETER	CONDITIONS	MIN.	TYP.	MAX.	UNIT
RF Frequency Range (Note)		4.9		5.9	GHz
Power Gain	Freq=5825 MHz		20.5		dB
S11 (Input Return Loss)			-11		dB
S22 (Output Return Loss)			-13		dB
P1dB	Freq=5825 MHz		20.5		dBm
Bias current @3.3V	Quiescent 64QAM/54Mbps, Pout=14dBm		150 175		mA
Sleep Mode current	Vcc = 3.3V, Vcntl = 0V		5		uA
Detector voltage range	Freq=5825 MHz 64QAM/54Mbps, Pout=10dBm 64QAM/54Mbps, Pout=16dBm 64QAM/54Mbps, Pout=20dBm		200 600 1000		mV
2 <sup>nd</sup> Harmonics	Freq=5825 MHz Pout=18 dBm Pout=20dBm		-34.5 -36		dBc
EVM	64QAM/54Mbps, Pout=14dBm		3		%

**Note 1:** Operation outside this range is possible, but not guaranteed

## Test Data & Diagrams

Over Freq. Test Data at Vcc=+3.3V,Temp.=+25°C, 11a, 54Mbps 64QAM OFDM

Gain vs Pout (Vcntl = 3.0V)

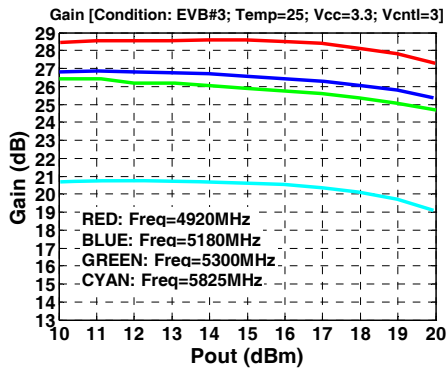

EVM vs Pout (Vcntl = 3.0V)

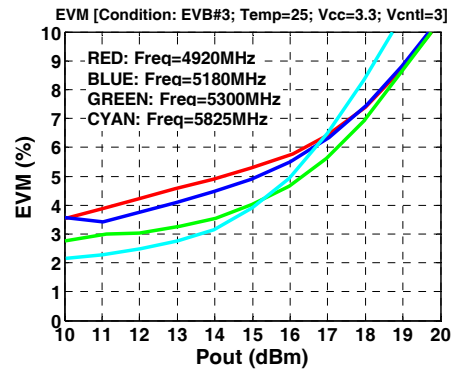

Icc vs Pout (Vcntl = 3.0V)

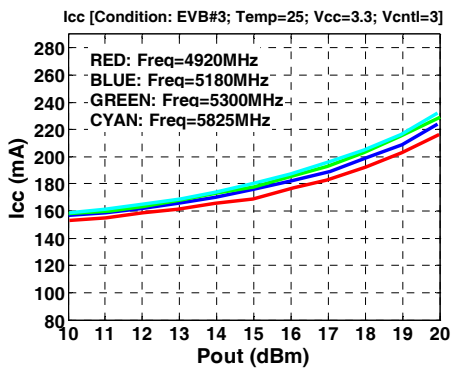

Vdet vs Pout (Vcntl = 3.0V)

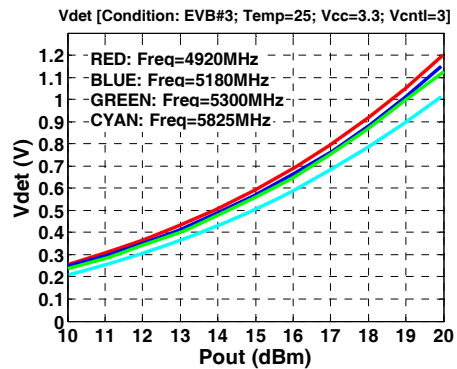

Over Vcc Test Data at Freq=5180MHz, Temp.=+25°C, 11a, 54Mbps 64QAM OFDM

Gain vs Pout (Vcntl = 3.0V)

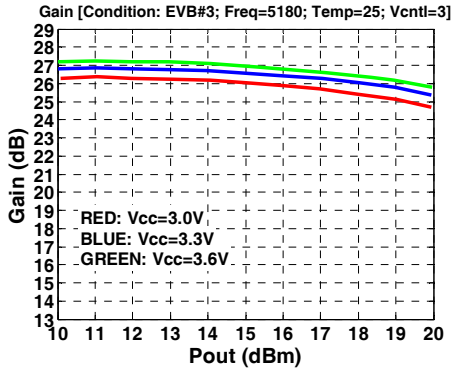

EVM vs Pout (Vcntl = 3.0V)

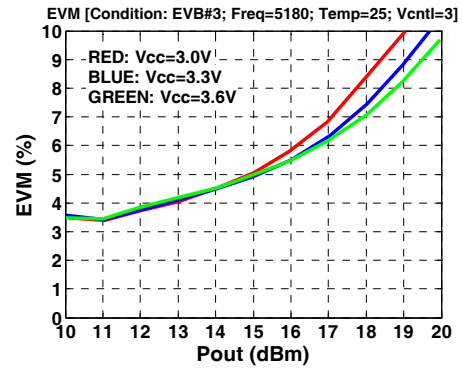

Icc vs Pout (Vcntl = 3.0V)

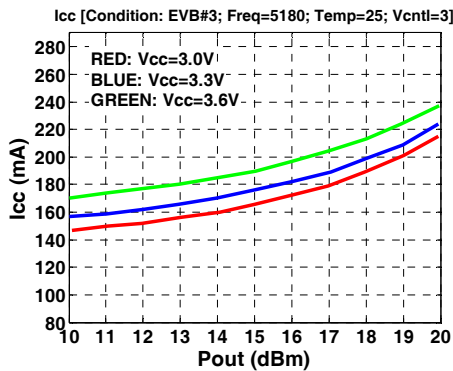

Vdet vs Pout (Vcntl = 3.0V)

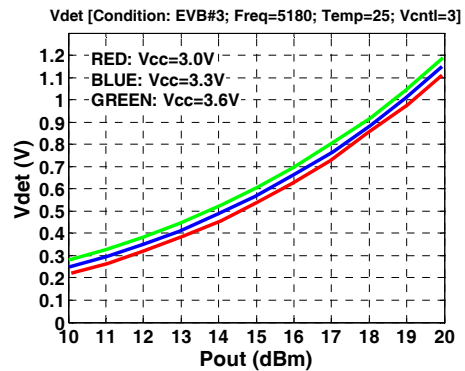

Over Vcc Test Data at Freq=5825MHz, Temp.=+25°C, 11a, 54Mbps 64QAM OFDM

Gain vs Pout (Vcntl = 3.0V)

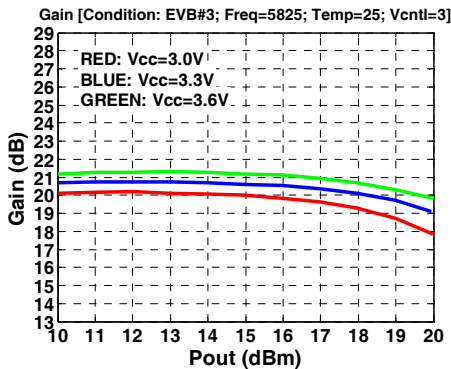

EVM vs Pout (Vcntl = 3.0V)

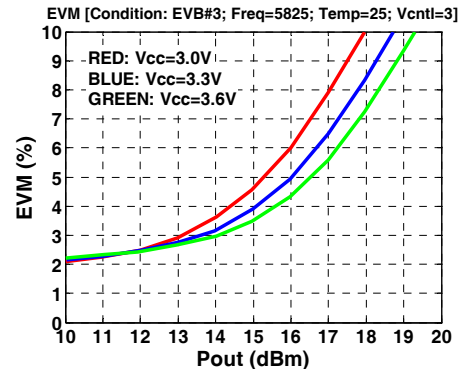

Icc vs Pout (Vcntl = 3.0V)

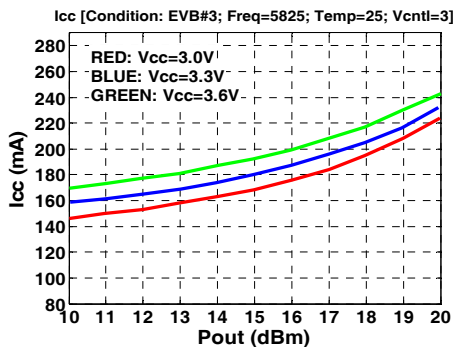

Vdet vs Pout (Vcntl = 3.0V)

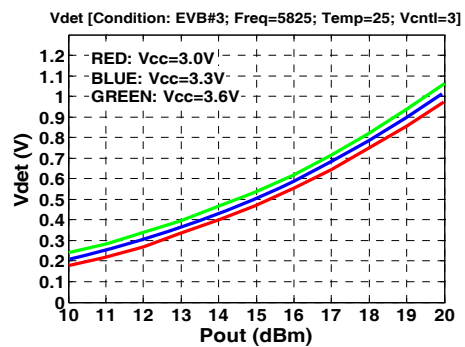

Over Temp. Test Data at Freq=5180MHz, Vcc=3.3V, 11a, 54Mbps 64QAM OFDM

Gain vs Pout (Vcntl = 3.0V)

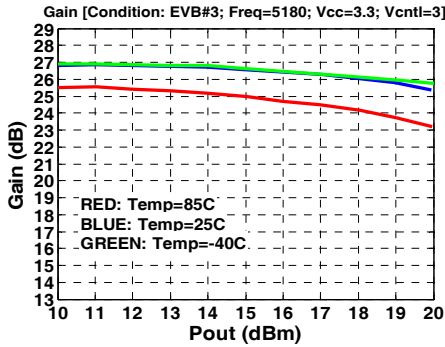

EVM vs Pout (Vcntl = 3.0V)

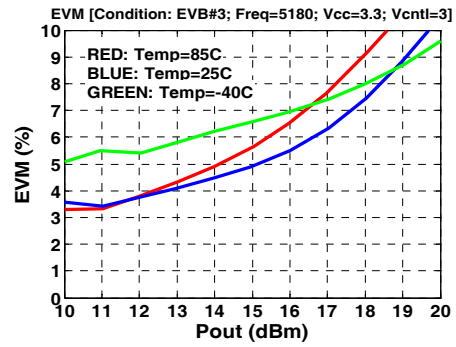

Icc vs Pout (Vcntl = 3.0V)

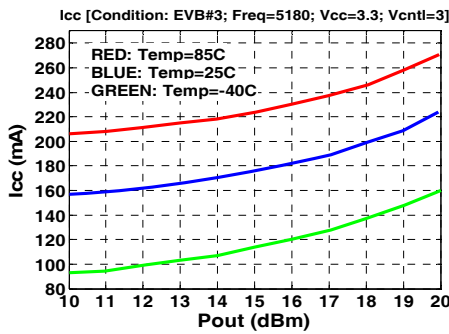

Vdet vs Pout (Vcntl = 3.0V)

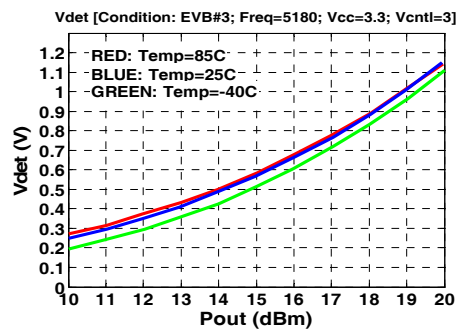

Over Temp. Test Data at Freq=5825MHz, Vcc=3.3V, 11a 54Mbps 64QAM OFDM

Gain vs Pout (Vcntl = 3.0V)

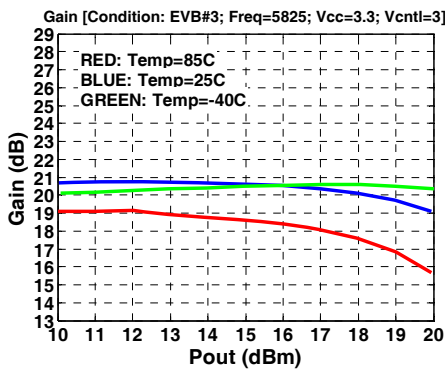

EVM vs Pout (Vcntl = 3.0V)

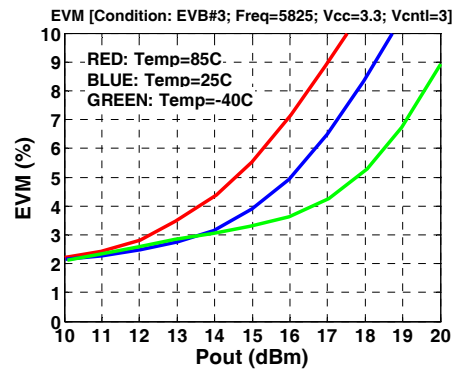

Icc vs Pout (Vcntl = 3.0V)

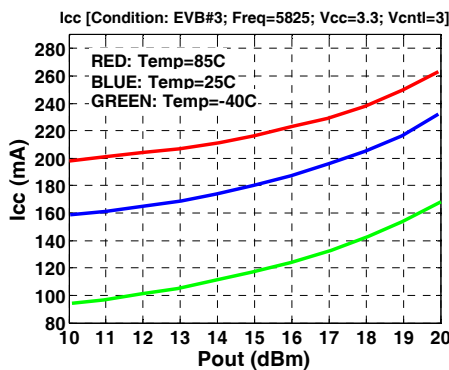

Vdet vs Pout (Vcntl = 3.0V)

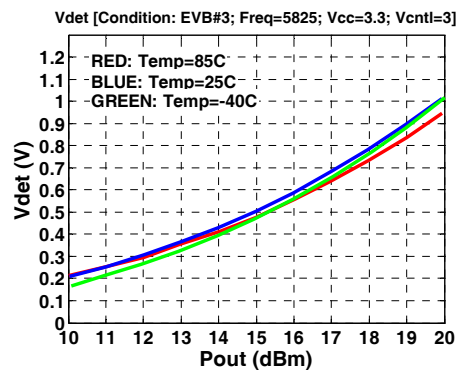

S-Parameters Test Data at Vcc=3.3V,Vcntl=3.0V

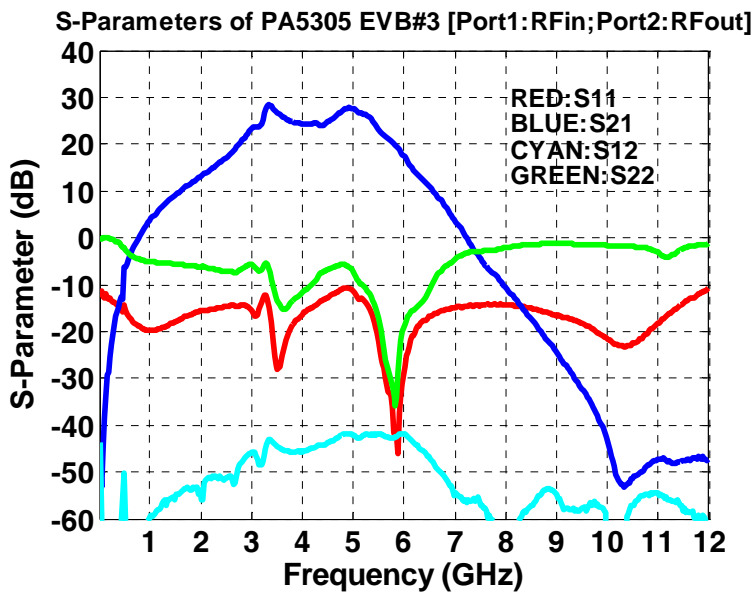

### Package Dimensions

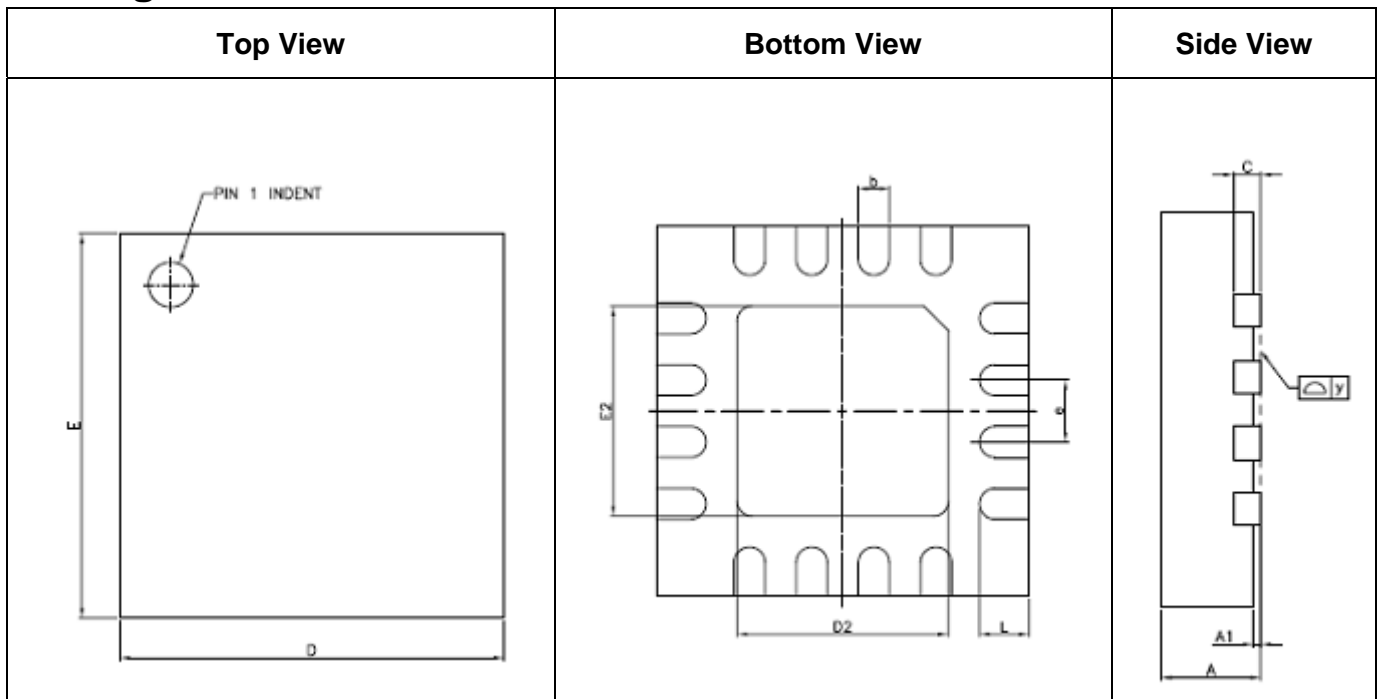

SYMBOLS	DIMENSIONS IN MILLIMETERS		
	MIN	NOM	MAX
<b>A</b>	0.70	0.75	0.80
<b>A1</b>	0.00	0.02	0.05
<b>b</b>	0.18	0.25	0.30
<b>C</b>	-	0.20 REF	-
<b>D</b>	2.90	3.00	3.10
<b>D2</b>	1.45	—	1.90
<b>E</b>	2.90	3.00	3.10
<b>E2</b>	1.45	—	1.90
<b>e</b>	—	0.50	—
<b>L</b>	0.35	0.40	0.45
<b>y</b>	0.00	—	0.075

## Application Note

Specified data on the datasheet is evaluated with configuration below. However, fine tuning may be required due to difference in the actual product board layout. Evaluation PCB design will be provided upon request. It is very important to make all RF and DC connections before applying RF or DC power. Use short, shielded twisted pair test leads to avoid interference.

The device is sensitive to ESD. The workstation should be ESD well-protected, when handling and assembly of this device.

## Typical Application Circuit

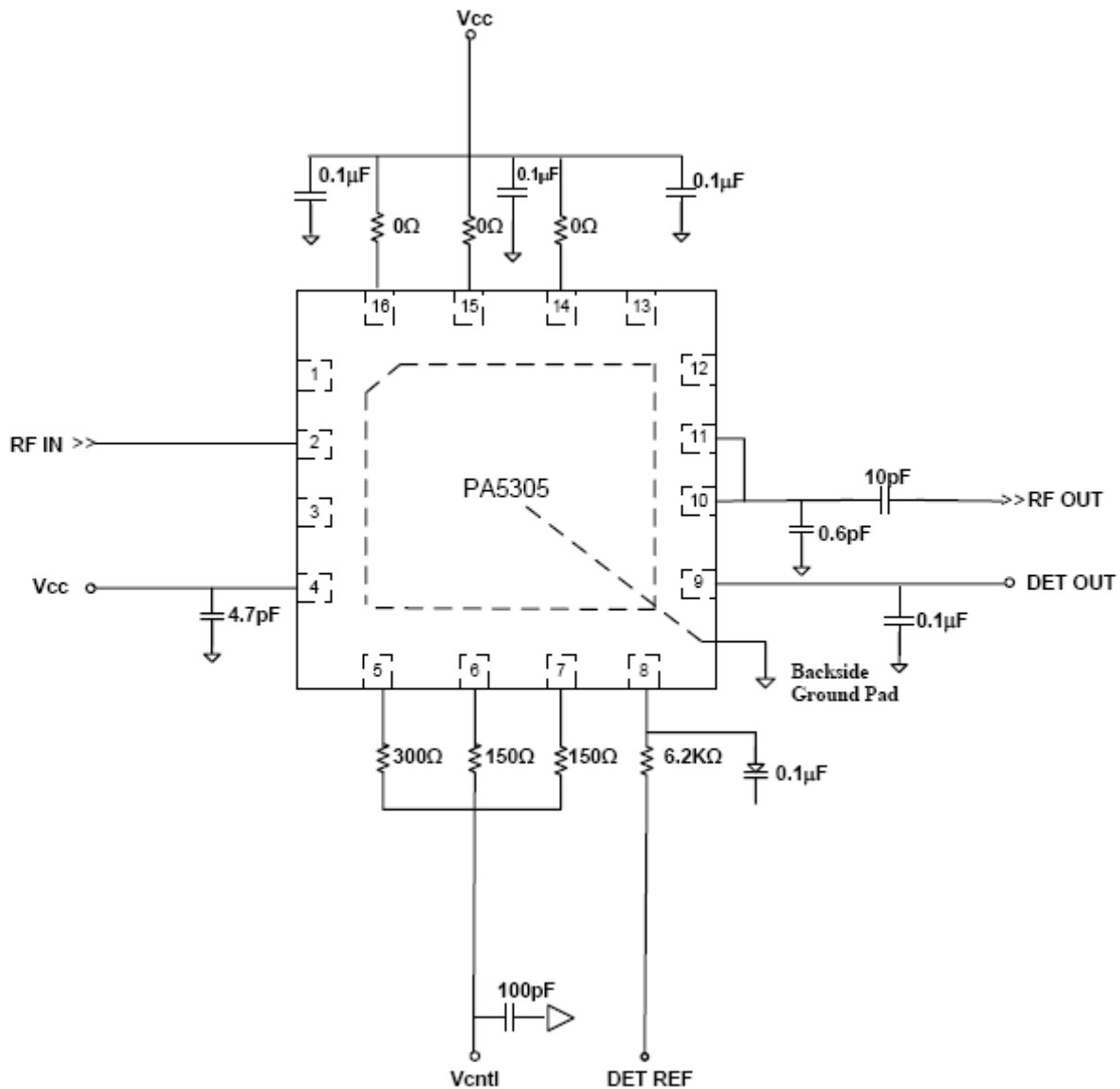

## Packing Information

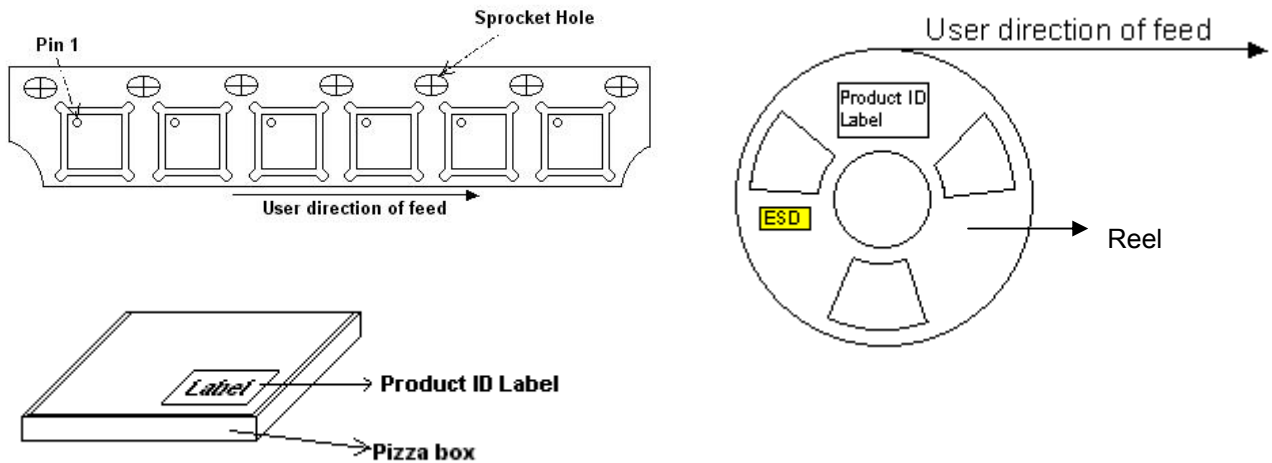

## Ordering Information

Ordering Number	Component Packing
PA5305	1,000pcs / Tape & Reel
PA5305-EVB	PA5305 Evaluation Kit

Epic Communications Inc. reserves the right to make changes to the product(s) or information contained herein without notice. The information contained in this document is considered to be accurate as of the date of publication. No liability is assumed by Epic Communications Inc. for use of any information contained in this document, or for infringement of any patent rights or any other proprietary rights of third parties which may result from such use.